

Estimating the Junction Temperature of AC LEDs

Yi-wei Liu, Asiri Jayawardena, Terence R. Klein, and Nadarajah Narendran

Lighting Research Center
Rensselaer Polytechnic Institute, Troy, NY 12180
www.lrc.rpi.edu

Liu, Y., A. Jayawardena, T.R. Klein, and N. Narendran. 2010. Estimating the junction temperature of AC LEDs. *Tenth International Conference on Solid State Lighting, August 1-5, 2010, San Diego, CA, Proceedings of SPIE 7784: 778409.*

Copyright 2010 Society of Photo-Optical Instrumentation Engineers.

This paper was published in the ***Tenth International Conference on Solid State Lighting, Proceedings of SPIE*** and is made available as an electronic reprint with permission of SPIE. One print or electronic copy may be made for personal use only. Systematic or multiple reproduction, distribution to multiple locations via electronic or other means, duplication of any material in this paper for a fee or for commercial purposes, or modification of the content of the paper are prohibited.

Estimating the junction temperature of AC LEDs

Yi-wei Liu*, Asiri Jayawardena, Terence R. Klein, Nadarajah Narendran
Lighting Research Center, Rensselaer Polytechnic Institute, 21 Union St., Troy, NY 12180 USA

ABSTRACT

Light-emitting diodes operating on alternating current are gaining popularity in the LED industry, especially for lighting applications. Because junction temperature is a good predictor of LED performance, the availability of a method to accurately estimate the junction temperature of AC LEDs would be very useful. This study investigated a method in which a low reference current having a pulse width of less than several milliseconds was applied and the corresponding voltage across the device was measured and correlated to the junction temperature. Laboratory experiment data showed that the proposed method is a promising candidate for estimating AC LED junction temperature.

Keywords: light-emitting diode, LED, alternating current, AC, junction temperature

1. INTRODUCTION

Alternating-current light-emitting diodes (AC LEDs) are one of the promising sources for lighting applications. Compared with lighting systems using direct-current light-emitting diodes (DC LEDs), AC LED lighting systems have the benefit of relative low overall cost because a driver is not necessary to convert AC wall-plug power to DC operation. However, like DC LEDs, the life of AC LEDs is influenced by heat dissipated in the junction. Predicting the junction temperature of the LED is essential to accurately characterizing LED performance within a lighting system. For DC LEDs, a considerable amount of research has been conducted to measure junction temperature and calculate thermal resistance. However, only a few papers have discussed concepts or methods to measure the junction temperature of AC LEDs. Zong et al. used an active heat sink for recovering the RMS current of the first half cycle to estimate the junction temperature of AC LEDs.^[1] Hwu et al. developed a method based on potential drop across the pn-junction and estimated junction temperature by measuring the board temperature.^[2] In this study, we developed an alternate method based on potential drop to measure the junction temperature and the thermal resistance of the AC LED package. In this method, a low reference current, 0.1 mA, having a pulse width of less than several milliseconds was applied at the zero-crossing point of the AC LED current waveform, and the corresponding voltage across the device was measured. Using this value and the calibration curve, the potential across the pn-junction versus junction temperature, the junction temperature was predicted. We then compared the results of this proposed method with the RMS current method.

2. METHOD

2.1 Experiment setup and calibration procedure for voltage drop method for AC LED

A commercial AC LED was attached to an active heating/cooling mount controlled by a temperature controller. A J-type thermocouple was attached using a thermal epoxy at a location closer to the die, as recommended by the manufacturer, to measure the pin temperature. The mount was heated to a known temperature, T_1 , and the corresponding voltage across the LED, V_1 , was measured by introducing a small DC reference current (0.1 mA). This procedure was repeated for 10 different temperature values and the corresponding voltage values were measured. Then the correlation between voltage and pin temperature was calibrated. A schematic of the experiment setup is shown in Figure 1. The LED was operated in a closed environment. A special circuit was designed to switch the LED input from AC voltage, DC voltage and AC voltage at the zero-crossing points, as shown in Figure 2. The DC pulse was very short, about 1.5 ms. During the DC input period, the average voltage (V_L) was measured. At quasi-steady state, the junction temperature was calculated based on the measured average voltage and the calibration curve.

* Email: liuy9@rpi.edu; Web: www.lrc.rpi.edu/programs/solidstate

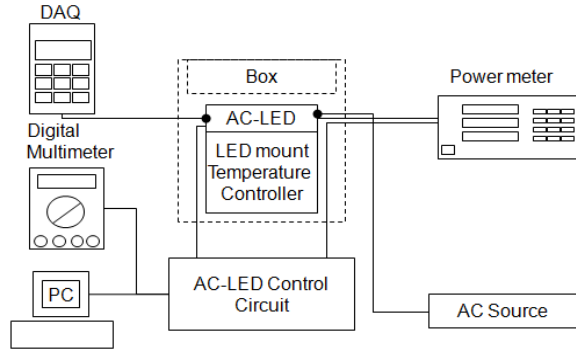

Figure 1. Schematic of experiment setup.

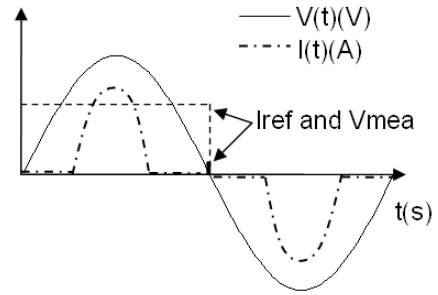

Figure 2. Zero-crossing point where reference current is applied.

To measure the voltage without changing the junction temperature, it is necessary to synchronize the circuit with AC operation and measure at the zero-crossing point. Figure 3 shows that the actual input power and calculated junction temperature are changing when applying the reference current at different points in the waveform by changing the phase delay constant. Figure 4 shows the actual measurement points in the waveform corresponding to the phase delay constants in Figure 3. Figures 5 and 6 show the voltage and current waveforms across the AC LED when the reference current is applied at phase delay constants of 35 and 76.

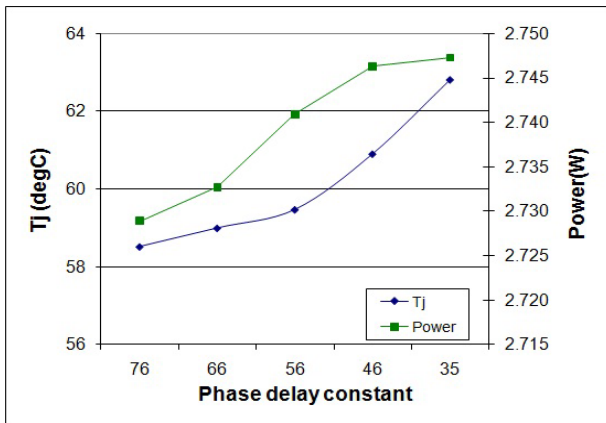

Figure 3 (left). Power and calculated junction temperature (T_J) at different phase delay constants.

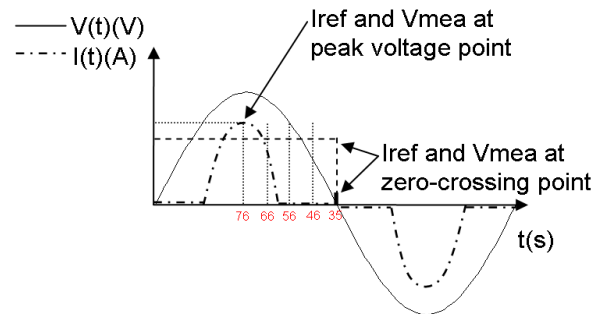

Figure 4 (right). Different phase delay constant points.

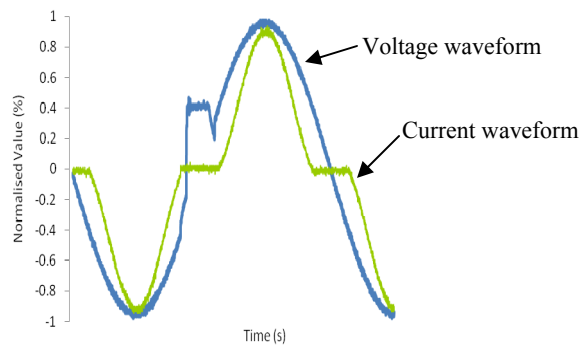

Figure 5 (left). Voltage and current waveforms when the reference current is applied at a phase delay constant of 35 (input power to the AC LED is not interrupted).

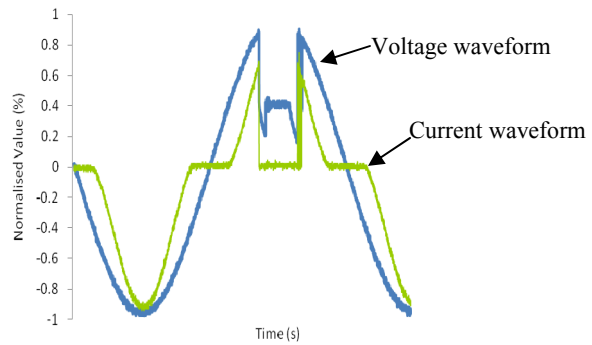

Figure 6 (right). Voltage and current waveforms when the reference current is applied at a phase delay constant of 76 (input power to the AC LED is interrupted).

2.2 Experimental procedure for recovering the RMS current of the first half cycle to estimate the junction temperature of AC LEDs using active heat sinks^[1]

The same commercial AC LED was mounted on an active thermoelectric cooler and the whole unit was placed inside an enclosed chamber. The AC LED was heated using the thermoelectric cooler with the AC LED turned off. A thermocouple was attached at the pin of the AC LED (as specified by the manufacturer). Once the pin of the AC LED was thermally stable, an AC voltage was applied starting from the zero phase to the AC LED. The first half cycle current waveform that was captured using a waveform digitizer with a sampling speed of 250 ks/S is shown in Figure 7. The digitized data was used to calculate the first half cycle RMS value of the current across the LED. The first half cycle RMS current was measured at different thermal pad temperature settings to validate the experimental setup by establishing the correlation between RMS current and thermal pad temperature, as indicated in Figure 8. The temperature of the thermoelectric cooler was adjusted to recover the initial half cycle RMS current. The pin of the LED was allowed to thermally stabilize at each adjusted temperature setting. RMS current across the LED was measured at every 1-second interval at steady-state operation. It was assumed that the pin and the junction of the LED were at the same temperature just before turning on the LED. When the initial half cycle RMS current was recovered, it was deduced that the junction had reached the initial temperature that existed prior to turning on the LED. Therefore, by comparing the pin temperature values prior to turning on the LED with those after the initial RMS current is recovered, the thermal resistance between the junction and the pin can be computed.

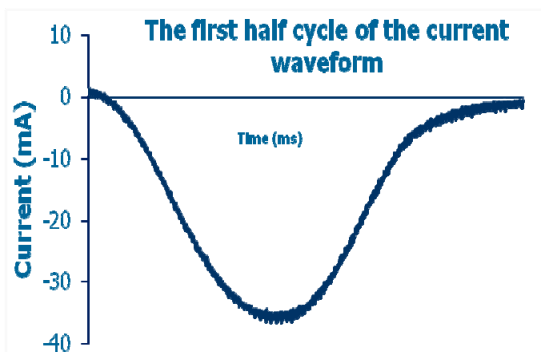

Figure 7 (left). The first half cycle of the AC current waveform applied across the AC LED.

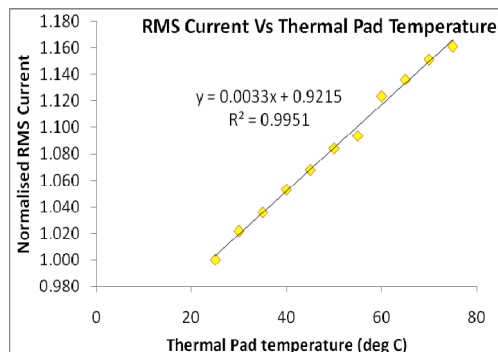

Figure 8 (right). The relationship between first half cycle RMS current with thermal pad temperature.

3. RESULTS

A calibration curve of a commercial AC white LED was created by following the experiment setup and procedure described earlier and is shown in Figure 9.

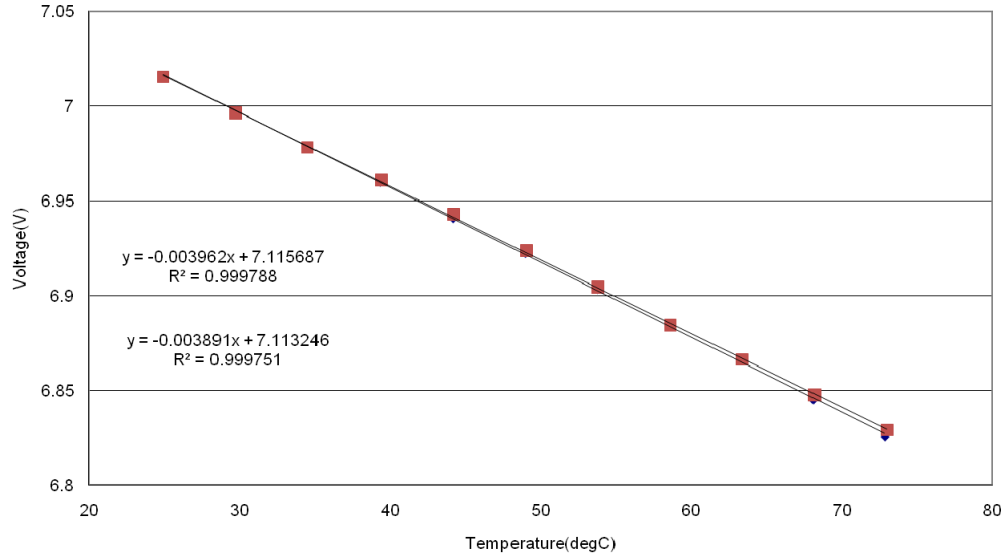

Figure 9. Calibration curve at different temperatures for the two input directions.

Table 1 shows the calculated junction temperature and the thermal resistance of a commercial AC LED at different pin temperatures, after considering optical power.

Table 1. Thermal resistance of a commercial AC LED at different pin temperatures.

T_{pin} (°C)	V_L (V)	Input Voltage (V)	Input Current (mA)	Power (Electrical-Optical) (W)	T_j (°C)	Thermal Resistance (°C/W)
34.6	6.9117	120.06	25.00	2.519	51.5	6.7
44.3	6.8702	120.06	25.77	2.631	62.0	6.7
54.1	6.8291	120.05	26.56	2.724	72.3	6.7
63.9	6.7861	120.05	27.36	2.818	83.2	6.8

Table 2 shows the results of the RMS current method for the same commercial AC LED. The initial pin temperature is the preset junction temperature in the RMS current method. After turning on the LED, when the RMS current was recovered, the recovered pin temperature was used to calculate thermal resistance.

Table 2. Thermal resistance calculation results using the method to recover the RMS current of the first half cycle to estimate the junction temperature of AC LEDs using active heat sinks at different initial pin temperature settings for the same commercial AC LED.

	Test 1	Test 2	Test 3
Initial Pin Temperature (°C)	46.6	56.2	65.8
Recovered Pin Temperature (°C)	37.4	48.7	56.9
Power (Electrical-Optical) (W)	2.4	2.5	2.6
Thermal Resistance (°C/W)	3.8	3.0	3.4

4. DISCUSSION

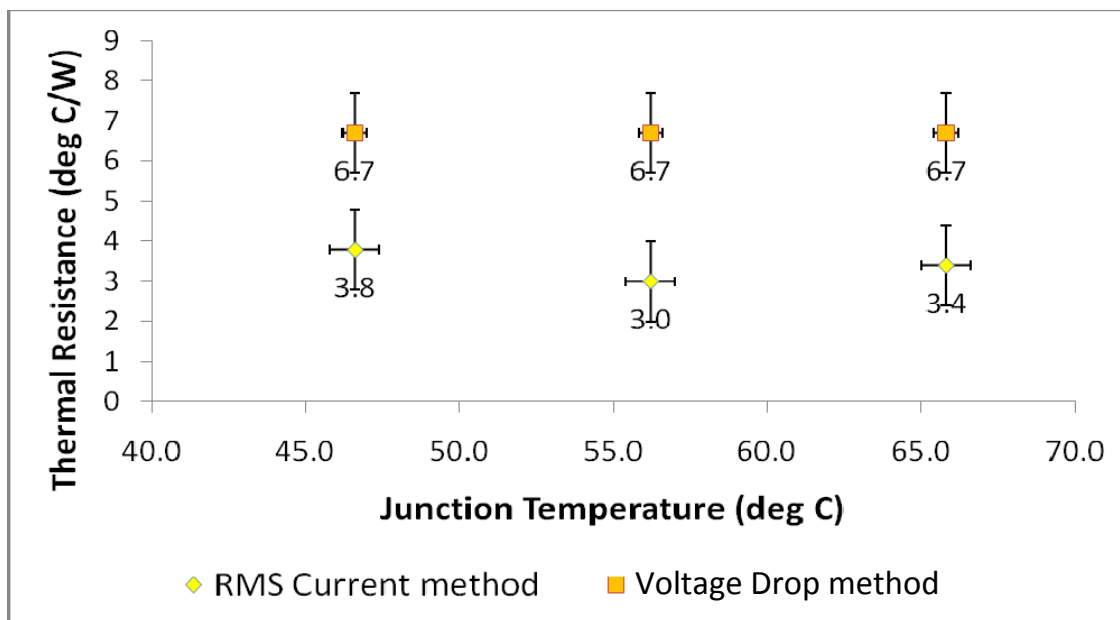

Figure 10. Comparison of thermal resistances of two different methods at different junction temperatures.

The thermal resistance measurements for the same AC LED are significantly different for the two different methods, as shown in Figure 10. The following reasons may have contributed to this difference:

Zong et al. claim that the junction temperature of the LED rises approximately 25% of the total rise within the first half cycle of the current waveform.^[1] This could be a significant amount of junction heating that could introduce a significant error in the thermal resistance measurements calculated by recovering the RMS current of the first half cycle to estimate the junction temperature of AC LEDs using active heat sinks. In order to estimate the impact of this initial heating in the junction, the AC LED mounted on the thermoelectric cooler was turned on at 25°C and was allowed to thermally stabilize without active cooling. The T_{pin} of the LED stabilized at 48°C, which is a 23°C temperature rise. If 25% of this temperature rise (6°C) occurs at the first half cycle of the RMS current and this is factored in to the R_{0j-p} measurement, the disparity in R_{0j-p} measurements using the two methods becomes narrower. Further studies are needed to ascertain the initial junction heating during the first half cycle of the AC current waveform in order to estimate the error it introduces on the thermal resistance measurement.

Even though the thermal resistivity is a property of the material, the thermal resistance is a function of the material resistivity's and geometry. It is specific to the heat flux network.^[3] In the voltage drop method, a static thermal

environment was maintained, whereas in the RMS current method, active cooling is used. Therefore, it can be argued that the two methods use two different thermal environments, and therefore the thermal resistance measurements are different. Preliminary experiments conducted by us and literature^[3] indicate that active cooling reduces the $R_{\theta j-p}$ value, which is also consistent with the results we obtained.

The method that uses active heat sinks to recover the RMS current of the first half cycle to estimate the junction temperature of AC LEDs is highly reliant on the accuracy of the instantaneous measurement of the current. A slight variation in the instantaneous measurement will cause a greater change in the final thermal resistance calculation. Repeated instantaneous measurements at different temperatures showed that the temperature-sensitive parameter for current is $70\mu\text{A}$ for every 1°C . This means that the accuracy of the thermal resistance measurement is significantly influenced by the resolution and accuracy of the measuring instruments and noise in the AC voltage supply. A 1% change in the initial half cycle RMS current measurement can introduce a 30% error in the thermal resistance measurement. The uncertainty of the thermal resistance measurements under the voltage drop method for AC LEDs was $0.4^\circ\text{C}/\text{W}$ with a 95% confidence interval. The uncertainty of the thermal resistance measurement using the method that recovers the RMS current of the first half cycle to estimate the junction temperature of AC LEDs using active heat sinks was $0.8^\circ\text{C}/\text{W}$ in this case with a 95% confidence interval.

ACKNOWLEDGMENTS

We thank Martin Overington and Tianming Dong of the Lighting Research Center for their support in the experiment setup. Jennifer Taylor of the Lighting Research Center is also thanked for her valuable help in preparing this manuscript.

REFERENCES

- [1] Zong Y., Chou P-T, Lin M-T, and Ohno Y., "Practical method for measurement of AC-driven LEDs at a given junction temperature by using active heat sinks," *Proc. SPIE* 7422, 742208-742208-7 (2009).
- [2] Hwu F-S, Sheu G-J, Lin M-T, and Chen J-C, "Method for determining the junction temperature of alternating current light-emitting diodes," *IET Sci. Meas. Technol.* 3(2), 159–164 (2009).
- [3] Sofia J.W., "Fundamentals of thermal resistance measurement," Internet: <http://210.34.23.24/download%5CThermal%5CFundamentals%20of%20Thermal%20Resistance%20Measurement.pdf> (1995).