

EXPANDING THE USE OF LEDs

The light-emitting diode (LED) is an emerging light source found currently in only a few applications, such as traffic lights and exit signs. As a relatively untested technology, luminaire manufacturers have been apprehensive about developing LED fixtures without a complete understanding of the technology and its performance.

The smaller size, cooler operation, and potentially longer life of LEDs makes this technology an ideal replacement for less efficient incandescent light sources, particularly in applications that require small or low-profile fixtures.

The Lighting Research Center (LRC), with co-funding from Westinghouse Lighting Corporation, developed and evaluated a prototype LED luminaire for elevators.



LED elevator lighting has the potential to achieve 25% greater efficiency than current incandescent elevator lights.

LOW-PROFILE LED ELEVATOR LIGHTING

THE LIGHTING RESEARCH CENTER INSTALLED PROTOTYPE LED ELEVATOR DOWNLIGHTS THAT PROVIDED SIMILAR ILLUMINATION LEVELS COMPARED TO INCANDESCENT FIXTURES WHILE CUTTING ENERGY USE 45%. ELEVATOR PASSENGERS FOUND THE LIGHTING TO BE ATTRACTIVE, STYLISH, BRIGHT, MODERN, COMFORTABLE, AND CLEAN-LOOKING.



Field study site: Empire State Hall at Rensselaer Polytechnic Institute.

The elevator selected for the field study used six LED downlights, each built with six white Luxeon 3W high-power LEDs and a custom-designed reflector. The LED downlights used 165 Watts in total, compared to 300 Watts for six incandescent downlights.

REDUCE MAINTENANCE AND ENERGY COSTS



LED Elevator Downlight

Benefits

- **Reduced maintenance**
 - Longer life, up to 40,000 hours
 - Rugged design resistant to elevator cabin vibration
- **Lower energy consumption compared to incandescent sources**
 - 45% savings compared to existing incandescent system
 - Efficacy of at least 18 lumens per watt
 - 28 GWh per year potential savings for California
 - Ability to work with on-demand dimming and motion-sensing lighting controls
- **Lower elevator manufacturing costs**
 - Low-profile fixtures can shorten the cabin height, reducing the amount of material needed to build the elevator shell
 - Smaller cabins mean smaller motors, a potential source of energy savings
- **Visual aesthetics**
 - Many color options
 - Potential for color-changing effects

INTERESTED?



Elevator manufacturers and cabin designers, building owners/managers, contractors, design engineers, code developers, and utility staff can use the information on LED elevator lighting.

Key next steps include:

- Work with Westinghouse Lighting Corporation to refine the design and select appropriate manufacturing processes.
- Educate elevator manufacturers and elevator cabin designers about the advantages of LED elevator lighting.
- Conduct additional field demonstrations with next-generation LED elevator fixtures.
- Consider the impact of LED low profile lighting on future codes and standards.
- Evaluate other LED low profile lighting applications.

This project is part of the PIER Lighting Research Program. For more information about PIER and its research activities, visit <http://www.energy.ca.gov/pier>.

Project results can be found on the following web sites:

- PIER contractor site:
www.archenergy.com/lrp/products/elevator.htm
www.archenergy.com/lrp/advlight_tech/project_2_3.htm
- Researcher project site:
www.lrc.rpi.edu/programs/solidstate/

Funded by the
California Energy Commission
Public Interest Energy Research Program

Contact information:

California Energy Commission
www.energy.ca.gov/pier
Don Aumann
daumann@energy.state.ca.us

Architectural Energy Corporation
www.archenergy.com/lrp
Judie Porter
jporter@archenergy.com

Lighting Research Center
Rensselaer Polytechnic Institute
www.lrc.rpi.edu
N. Narendran
narenn2@rpi.edu

Arnold Schwarzenegger, *Governor*
California Energy Commission
Chairman: William J. Keese
Commissioners: Arthur H. Rosenfeld, James D. Boyd,
John L. Geesman, Jackalyn Pfannenstiel

LED LOW PROFILE FIXTURES

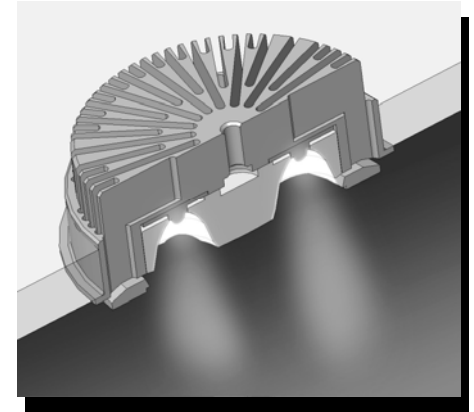

AN INNOVATIVE
APPLICATION
FOR LED LIGHTING



Public Interest
Energy Research