

Specifier Report: CFL Residential Downlights

Downlights are the predominant luminaire used in both residential new construction and remodeling. Higher claimed efficacy and reduced maintenance provided by compact fluorescent lamp (CFL) technology make CFL downlights a logical choice. However, of the 400 million downlights installed in homes today, most use incandescent lamps.

Specifier Report: Downlights presents photometric, electrical, and thermal performance data for selected CFL residential downlights. The report covers fixtures eligible to earn ENERGY STAR® approval under version 4.0 of the Residential Lighting Fixture specification.

CFL downlights can function as fixed luminaires, projecting light downward onto horizontal surfaces, or as wallwashers for vertical surfaces. Most downlights consist of a housing, lamp socket, CFL, ballast, and junction box for wiring. Baffles, reflectors, and lenses can enhance appearance but may affect performance.

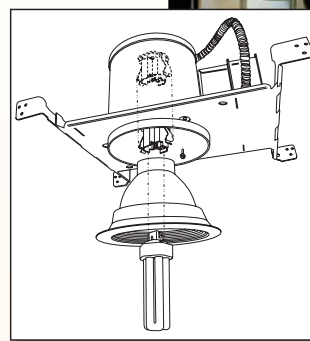

Above: Recessed downlights installed in a kitchen

Left: Exploded view of recessed downlight assembly

Testing

NLPIP evaluated pin-based CFL recessed downlights to better understand the effects of elevated temperatures on system performance. The report provides a detailed description of the testing procedures for photometric, electrical, and temperature measurements and a description of supplementary pilot testing. The accessories test studied the effects on system efficacy of different trims, baffles, and lenses. The screwbase lamps test studied the system efficacy of a screwbase ICAT luminaire using different types of lamps.

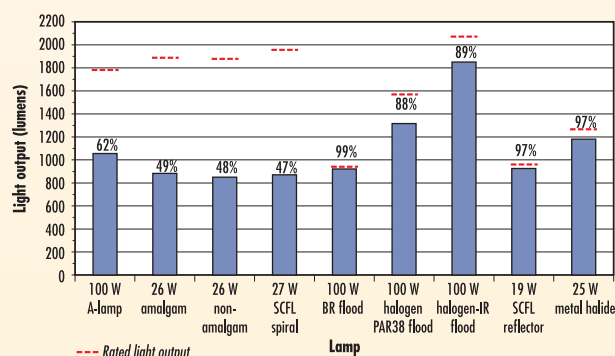

Test results show system efficacy for various lighting systems. Actual system light output is shown as a percentage of the lamp's rated output.

Results

- Ballast case temperatures measured below the manufacturers' maximum recommended values, both in open-air and when installed in test boxes.
- Luminaire light output measured in test boxes averaged 44% below maximum possible light output values.
- Calculated average system efficacies = 31.7 LPW
- Light output and system efficacy was lower for trims with black baffles and for both the Fresnel lens and the diffuse glass lens.
- System efficacy for reflector lamps, whether CFL, incandescent, or metal halide, averaged 94% compared to 52% for their A lamp, spiral, amalgam, and non-amalgam counterparts.

Sponsors

- California Energy Commission's PIER Program
- Iowa Energy Center
- New York State Energy Research and Development Authority
- U.S. Environmental Protection Agency



View LRC Project Sheets at
www.lrc.rpi.edu/resources/newsroom/projectsheets.asp

Lighting
Research Center