

ASSIST recommends...

Efficiency Testing for Freezer Case Lighting

Supermarkets use lighted cases to store and display refrigerated and frozen products. LEDs are now becoming common light sources in this application. Current industry practice rewards freezer lighting for its luminaire efficacy measured at room temperature. To obtain realistic data, the evaluation method must consider the application environment.



ASSIST has published a technology-neutral method for evaluating the performance of luminaires used in freezer cases.

Application Efficacy Method

ASSIST's method calls for measurements of the luminous flux reaching the face of the merchandise. A 60-inch by 60-inch area with 6-inch grid squares was built for illuminance measurements. Measurements are first taken at room temperature (22°C). A scaling factor using the relative light output measured at the proper cold temperature is applied to the room-temperature measurements to estimate the cold application's luminous flux. The luminaire input power and the extra freezer power required to dissipate heat from the luminaire are used to calculate the luminaire's application efficacy.

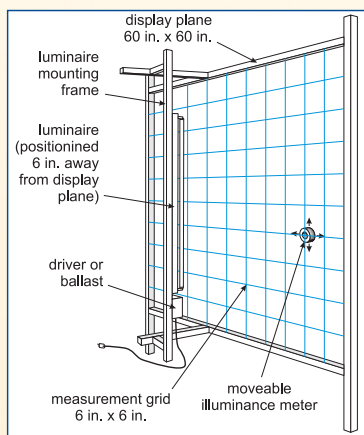

Download ASSIST recommends... Publications
www.lrc.rpi.edu/assist

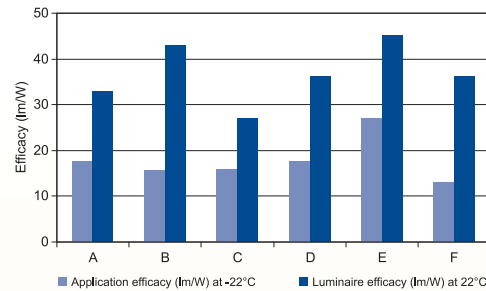

Luminaire efficacy compared with application efficacy for six commercial LED freezer case luminaires

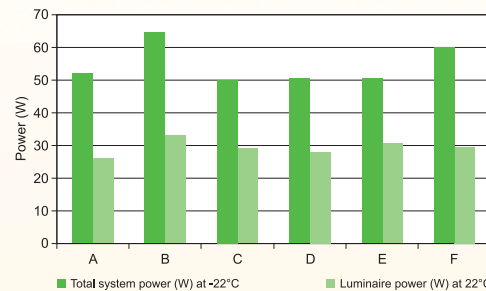

Luminaire power compared with total system power for six commercial LED freezer case luminaires

Performance Comparisons

Six commercial LED freezer case luminaires were tested following ASSIST's method. Comparisons were made between luminaire efficacy and application efficacy and between luminaire power and total system power at both room temperature (22°C) and freezer temperature (-22°C). The results show significant performance differences between room and application (freezer) temperature. For example, luminaire B has better room temperature luminaire efficacy (42 lm/W) than luminaire C (28 lm/W). However, when both luminaires are compared under cold application conditions, luminaire B's application efficacy is slightly lower and requires 30% more power.

Sponsor

ASSIST

